

HVAC Lightsystem Inspection Window

P/N: 5071-5030115-000

For Inspection Window Square

P/N: 506002-40 / 506002-50 / 506002-60

Technical specifications

- 100 Lumen, 6 LED
- Up to 200 cycles/battery pack
- 2 x battery size AAA
- Protection classification IP54

Alternative power supply

- 5V DC 500mA (not included)

Included in the shipment

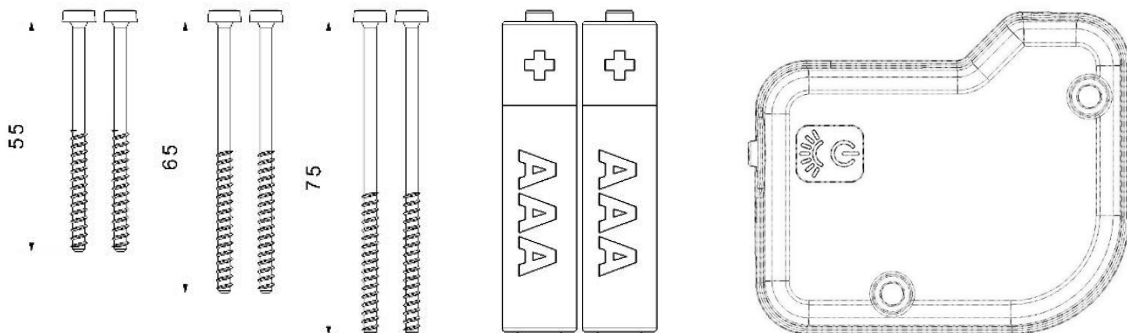

Inserting batteries

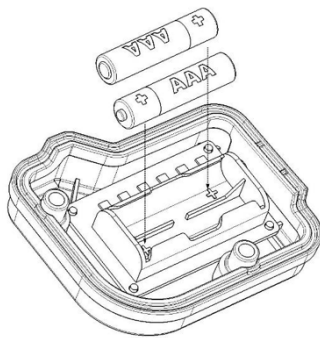

Possible assembly positions

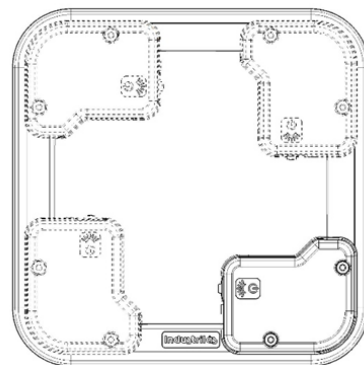

Assembly instructions

Disassembly screws

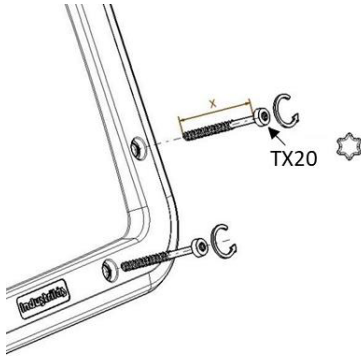

Mounting of the lightning system

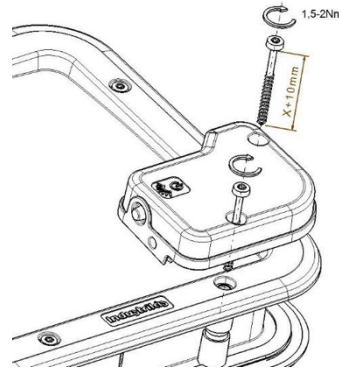

Power on

Automatic switch-off
after 30 seconds

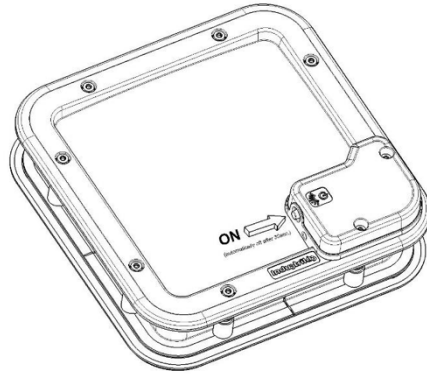

Alternative power supply

Remove batteries before use
with external power supply

Soldering cable

