

VECTOR P 转舌锁



本专利重型桨式门锁提供左开、右开或适用握柄选择。锁具机构将凸轮牢固地锁在冲击座后面，并且施加在凸轮上的力越大，凸轮就越难与冲击座接合。使用固定架或四枚模压螺栓安装。防水和防尘等级达到 IP66。标准配备相似钥匙上锁的 805 锁芯。拔取钥匙：开启/闭合 提供内侧释放安全功能。这样一来，即使在上锁状态下也可以从内部打开门锁。



材质

Adapter for cylinder (internal component): 尼龙6+30%玻纤

锁体: Zinc die cast, black or silver texture powder coated

Cam: Steel, zinc plated or unplated

嵌入式螺栓: 钢, 镀锌

Cylinder: Brass, nickel plated in matt finish

Gaskets: Polyurethane

把手: Zinc die cast, silver grey coated

Manoeuvre arms: 锌合金, 镀锌

安装托架: 钢, 镀锌

螺母: Zinc die cast, chrome

O-ring: NBR

Striker: Zinc die cast, zinc plated or black powder coated

相关产品

类似产品: 2-834

附件产品: 2-412

索引编号见网站 industrilas.com

TESTS & STANDARDS

The tightening torque of the two nuts for the mounting bracket is 3,0 Nm. The tightening torque of the four nuts for the mould-in bolts is 2,2 Nm. It is important that the four holes made in the cut out for the mould-in bolts are within tolerance, to avoid damage when tightening the M5 nuts.

标准: IP66, DIN EN 61373

钥匙信息: Supplied keys: 2, Cylinder with other key codes on request

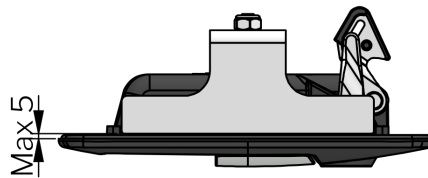
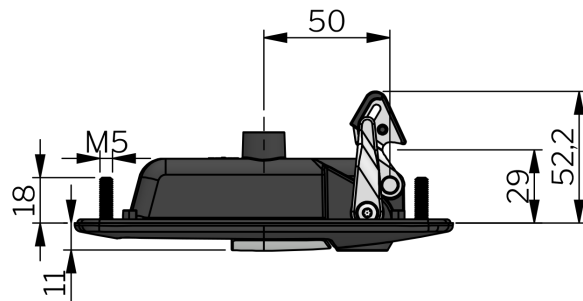
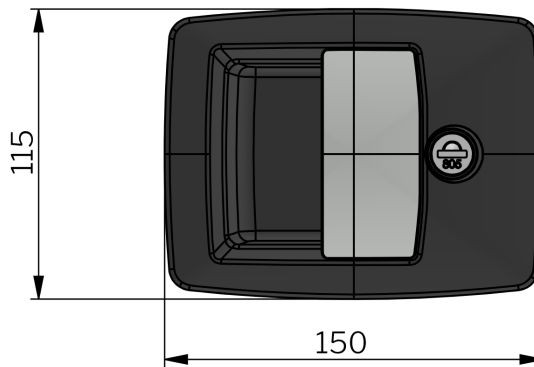

Industrilas
— When access counts —

每一栏选择对应的数字创建产品编号 (AAAA-BBCDDE-FFGG)

AAAA 款式	BB 把手	材质	C Mounting	DD Cam	E 款式	FF Cylinder type	GG Striker H L
2800 VECTOR - Paddle	00 Universal	PA6	1 Mould-in bolts	02 Fixed cam to prevent inside opening	0 Standard	01 805	01 是 16 55
	01 Universal	锌合金, 镀铬	2 安装托架	03 Cam with inside safety release		02 455	00 否 - -
	02 Universal	Zinc die cast, black				03 不同钥匙	
	10 Left	PA6				06 CH751	
	20 Right	PA6				69 Keyed alike 810	
						70 Keyed alike 815	
						71 Keyed alike 820	
						72 Keyed alike 825	
						73 Keyed alike 830	
						74 Keyed alike 835	
						75 Keyed alike 840	
						76 Keyed alike 845	
						77 Keyed alike 850	

