

# 人体工程学轮廓 VISION 旋转把手

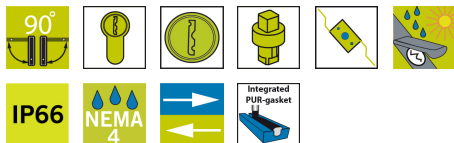

薄型旋转把手，适用于带有控制机构和锁杆的锁具系统。它可与 40 毫米型材锁芯配合使用，或配备按钮或工具上锁插入件。锁芯、按钮或插入件位于旋转把手盘内，使把手操作更加符合人体工程学。

把手采用弹簧加压，在解锁或按下按钮时会弹出。锁芯上覆盖滑动防尘罩。依据 NEMA 4，防水等级达到 IP65。



## 材质

Dish: 尼龙6+30%玻纤

Dust cover: TPE

把手: Zinc die cast, silver grey coated

O-ring: NBR

Push button: 尼龙6+30%玻纤

## 相关产品

类似产品: 1-005.15

Rod latch systems: 1-008.04, 1-008.05, 1-

008.13, 1-008.21, 1-008.25, 1-008.07

Cylinders: 1-209, 1-210, 1-211

索引编号见网站 [industrilas.com](http://industrilas.com)

## TESTS & STANDARDS

开口尺寸: Version C

Model with profile cylinder:

Turn-to-latch = The door is locked by turning the key.

Model with insert, push-button or round cylinder:

Push-to-latch = Spring loaded cam latches when the handle is pushed in.

T = For door thickness: 0,8-3,5 mm.

\* Handle supplied without profile cylinder.

标准: IP66, NEMA 4

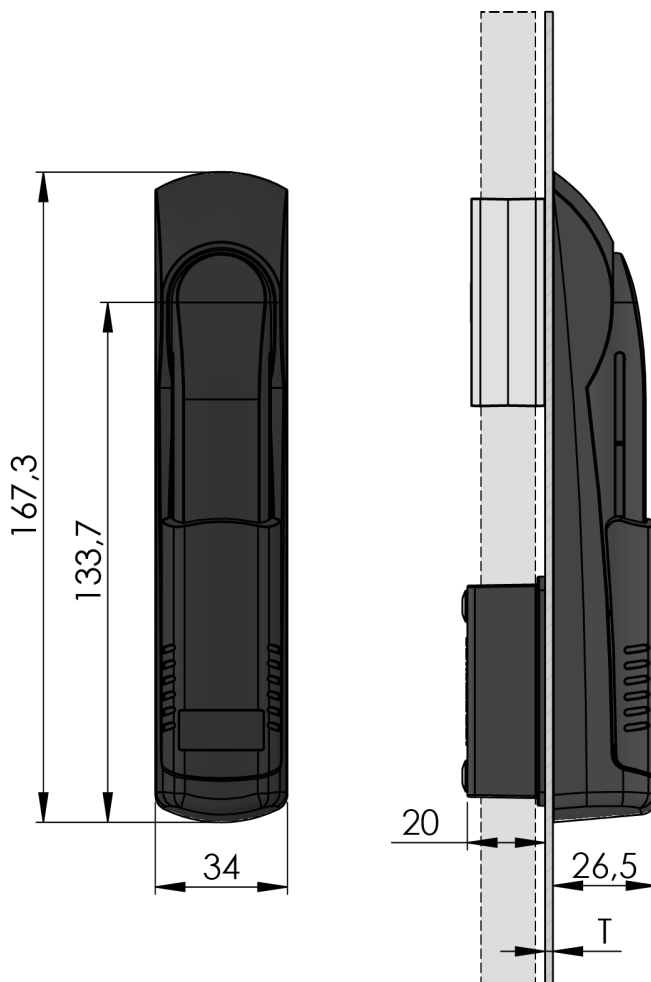

**Industrilas**  
— When access counts —

每一栏选择对应的数字创建产品编号 (AAAA-BBCDE-FF)

AAAA 款式	BB Insert / Cylinder	C Surface treatment insert	D Protection degree	E 门厚度	FF Serial Number
1530 Handle for control mechanism	35 内六方形 10	3 镀铬	0 IP54	3 2,6 - 3,5 mm	00 Standard Suffix
	34 内六方形 8	6 Black powder coated			
	29 Slotted, Recessed	2 Chrome plated		2 1,6 - 2,5 mm	
	32 Hexagon 11			1 0,8 - 1,5 mm	
	80 不同钥匙 *				
	84 For Oval Cylinder				
	90 Push Button				
	83 For profile cylinder				
	81 相同钥匙 IL101				
	82 相同钥匙 IL0333				
	26 直槽				
	05 四方形 8				
	07 Square 8 / slotted				
	02 四方形 7				
	01 四方形 6				
	03 四方形 7				
	11 Square 8 / Recessed				
22 双翼 3					
24 双翼 5					
16 三角形 10					
15 三角形 8					

Version C

