

# KLIMA-FLEX 1 LATCH UNIT STAINLESS STEEL



The Klima-flex system is designed for quick and easy mounting in insulated doors. The cam can be placed anywhere on the threaded area of the shaft using counter nuts. See drawing and table below for positioning of cams and cutout. The stainless version has a special cutout seen on the drawing.

The Klima-flex latching unit is fixed with a starlock washer.

Inside option: all latching units can be completed with an inside handle, roller cam and a rod link.



## MATERIAL

**Cam:** Stainless steel 304

**Collar:** Glass fibre reinforced Polyamide (PA6GF30)

**Nut:** Stainless steel 304

**Shaft:** Stainless steel 303

**Washer:** Glass fibre reinforced Polyamide (PA6GF30)

## RELATED PRODUCTS

**Handles:** 2-310ab, 2-310c

**Roller cams:** 2-312cd

**Interlink rods:** 2-313a

**Rod links:** 2-313b

Use the Index Code at [industrilas.com](http://industrilas.com)

## TECHNICAL INFORMATION

**Standards:** VDI 6022

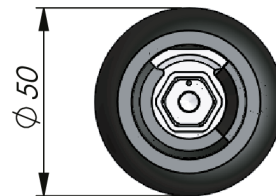
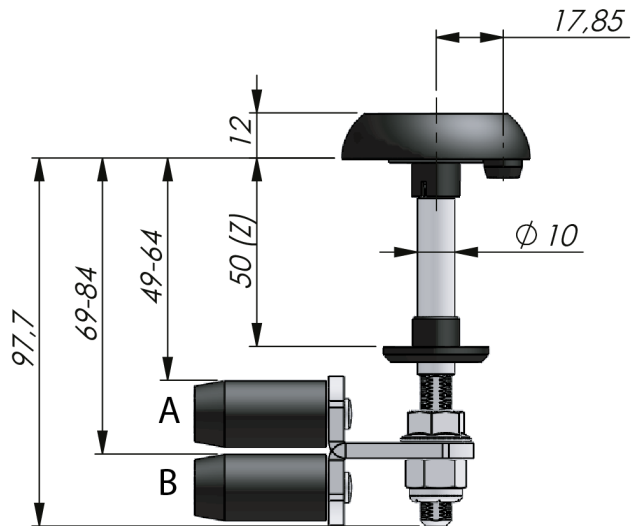

P/N	Description	Shaft	Cam	Door thickness
263079-S25-G40	Round shaft	Stainless	Adjustable	25 mm
263079-S30-G40	Round shaft	Stainless	Adjustable	30 mm
263079-S50-G40	Round shaft	Stainless	Adjustable	50 mm
263079-S60-G40	Round shaft	Stainless	Adjustable	60 mm

**Industrilas**  
— When access counts —

**Max/Min Measurements for Stainless Cams on Stainless Latching Units - System KLIMA-FLEX**

<b>Latching unit</b>	<b>Cam</b>	<b>Grip range *</b>	<b>Cam</b>	<b>Grip range *</b>	<b>Cam</b>	<b>Grip range *</b>
263079-S25-G40	2330S07-R05	A=22-38 B=42-58	2330S07-R08	A=8-25 B=35-51	2330S07-R01 or 2330S07-R06	A=1-17 B=43-59
263079-S30-G40	2330S07-R05	A=27-43 B=47-63	2330S07-R08	A=13-30 B=40-56	2330S07-R01 or 2330S07-R06	A=6-22 B=48-64
263079-S50-G40 **	2330S07-R05 **	A=47-63 B=67-83	2330S07-R08	A=33-50 B=60-76	2330S07-R01 or 2330S07-R06	A=26-42 B=68-84
263079-S60-G40	2330S07-R05	A=57-73 B=77-93	2330S07-R08	A=43-60 B=70-86	2330S07-R01 or 2330S07-R06	A=36-52 B=78-94