

KLIMA-FLEX 2 LATCH UNIT



Industrilas Klima-flex™ 2 has patented technology that allows for quick mounting in double-skinned doors. When you turn the screw, expanding legs are engaged and fix both door skins from the inside.

Both inside and outside handles can be mounted onsite and you can add a rod link or safety catch with no changes to the latching unit. The use of roller cams reduces the friction in the latching operation and increase the gasket compression.



MATERIAL

Latching unit: Zinc, zinc plated and glass fibre reinforced Polyamide (PA6GF30), black
Screw: Steel, zinc plated

RELATED PRODUCTS

Interlink rods: 2-313a
Handles: 2-315d
Inside options: 2-315f
Cams: 2-315e
 Use the Index Code at industrilas.com

TECHNICAL INFORMATION

Standards: VDI 6022
 Cover plug is used to cover latching point when handle is not used.
 Small hole towards hinge side of door.

Cutout: K-Flex 2

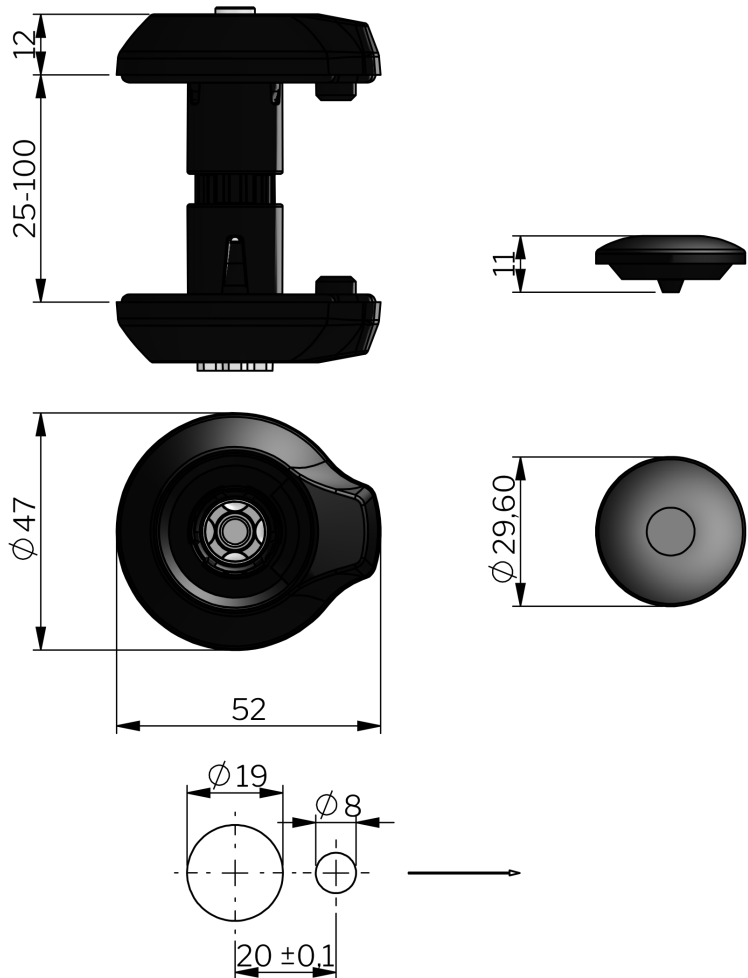

P/N	Description	Door thickness
2651-101025	K2 latching unit	25 mm
2651-101030	K2 latching unit	30 mm
2651-101035	K2 latching unit	35 mm
2651-101043	K2 latching unit	43 mm
2651-101045	K2 latching unit	45 mm
2651-101050	K2 latching unit	50 mm
2651-101060	K2 latching unit	60 mm
2651-101070	K2 latching unit	70 mm
2651-101075	K2 latching unit	75 mm
2651-101095	K2 latching unit	95 mm
2651-101100	K2 latching unit	100 mm

Door thickness tolerance $\pm 2,5$ mm.