

INSPECTION WINDOW CIRCULAR



Circular inspection window in transparent, impact-resistant polycarbonate. Intended for HVAC-applications using insulated or double-skinned doors. The window is equipped with an integrated gasket and is suitable for units with positive or negative pressure. The window is delivered in two halves that are assembled in the door with a $\varnothing 182$ mm hole. Simple mounting by using the included bolts and nuts.

Diameter for circular placement of mounting holes is 195 mm.



MATERIAL

Nut: Stainless steel 304
Screw: Stainless steel 304
Sealing: Foamed PUR-gasket (polyurethane)
Window: Polycarbonate/Macrolone 6557, crystal clear and impact resistant

RELATED PRODUCTS

Similar products: 5-252
 Use the Index Code at industrilas.com

TECHNICAL INFORMATION

Customer logo may be included upon request.
 Door thickness tolerance: ± 2 mm.

Standards: VDI 6022

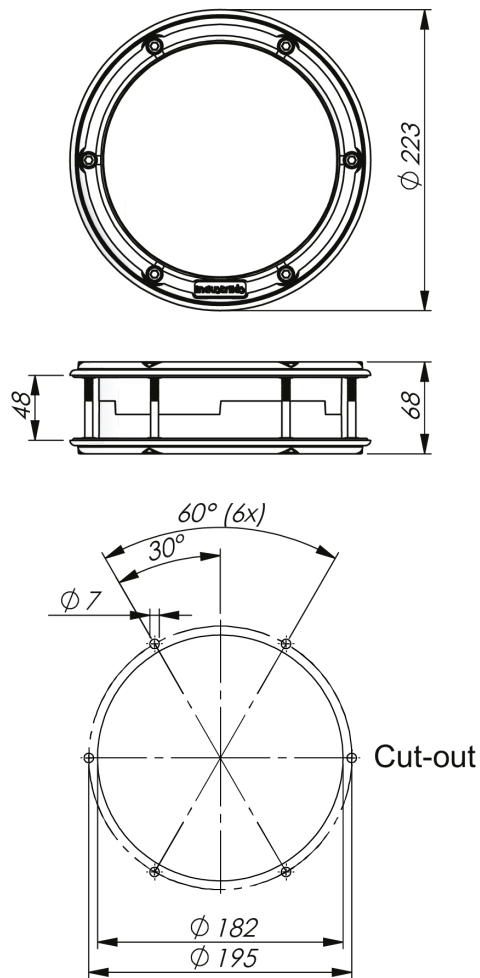

P/N	Door thickness	X in mm
506001-48	48 mm \pm 2 mm	68 mm