

## VECTOR T2 DEFEATER HANDLE



The heavy-duty Vector T2 Defeater handle is designed with a spring-loaded tool operated insert to prevent accidental opening. Only while the spring-loaded insert is turned and held in the unlocked position the handle can be opened.

The handle can be turned 180° left and right and provide 4 mm compression. You can use fixed or adjustable cams and choose between one-point, two-point and three-point cams.

Installation is swift with a mounting bracket. Dust and water protected according to IP65.



### MATERIAL

**Adjustable cam:** Zinc die cast, passivated

**Assembly hardware:** Steel, zinc plated

**Body:** Glass fibre reinforced polyamide (PA6GF30)

**Cast-in bolts:** Steel, zinc plated

**Fixed cam:** Steel, zinc plated

**Handle:** Zinc die cast, chrome plated or black texture powder coated

**Insert:** Zinc die cast, chrome plated or black texture powder coated

**Mounting bracket:** Steel, zinc plated

**Nut:** Steel, zinc plated

**Roller:** Glass fibre reinforced polyamide (PA6GF30)

### RELATED PRODUCTS

**Similar products:** 2-800, 2-810, 2-820, 2-811

**Rods:** 2-540, 2-541, 2-545

**Rod guides:** 2-560, 2-570

**Rod adapters:** 2-541

Use the Index Code at [industrilas.com](http://industrilas.com)

### TECHNICAL INFORMATION

The tightening torque of the two nuts for the bracket is 3 Nm.

**Standards:** IP65, DIN EN 61373

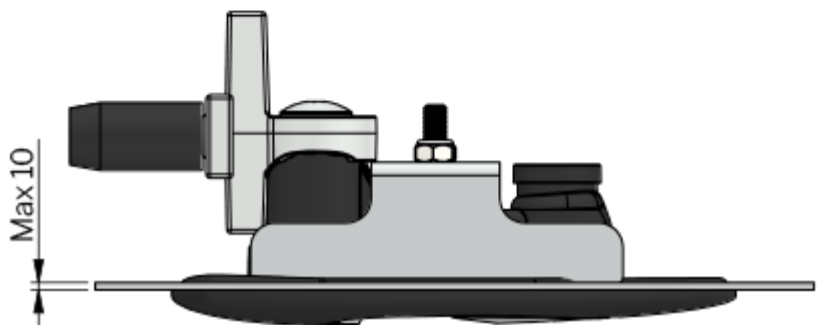
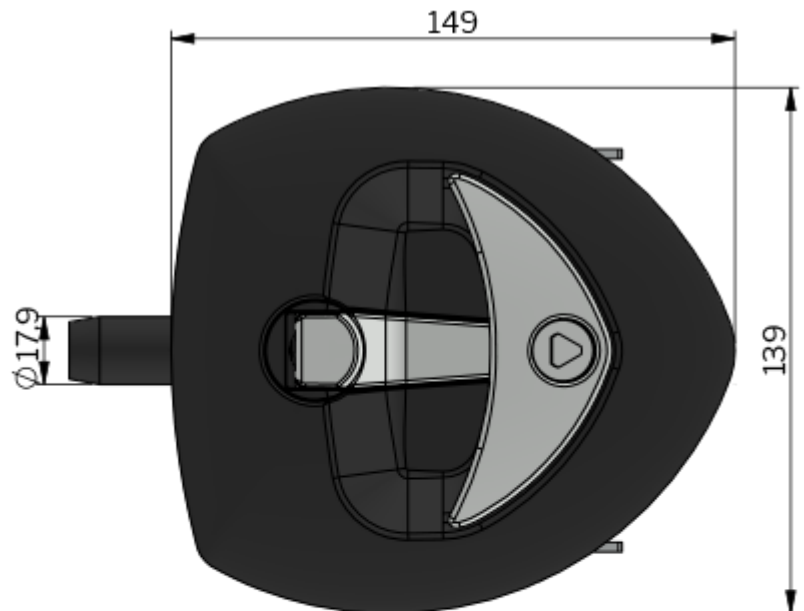

**Industrilas**  
— When access counts —

**Make your selections in each column to create your article number (AAAA-BBBCC-DDDDD)**

AAAA Type	BBB Handle material, finish	CC Insert	DDDDD Cam	H=	L= Drawing
2751 Vector 2	102 Zinc die cast, chrome plated	15 Triangle 8	1861 Fixed one-point cam	18	61 C
	106 Zinc die cast, black powder coated		2361 Fixed one-point cam	23	61 C
			4661 Fixed one-point cam	46	61 C
			4861 Fixed one-point cam	48	61 C
			5361 Fixed one-point cam	53	61 C
			S4600 Two-point cam	-	- D
			S Adjustable three-point cam	17-65	65 B
			S1 Adjustable one-point cam	17-52	65 A

