

# ADJUSTABLE CAM

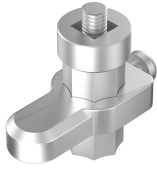

Adjustable cam that can be assembled on all quarter-turn latches for combi cut-out including L-handles, T-handles and knobs. Available both for latches requiring cam with projection and for latches requiring cams without projection. Provides 23 mm adjustability and between 21,5 – 45 mm for latches with 18 mm housing depth. Cam is secured at chosen grip range with a set-screw.

Both set-screw and screw to attach the adjustable cam to the latch are supplied as Phillips head screws.



## MATERIAL

**Cam:** Zinc die cast, zinc plated

**Screw:** Steel, zinc plated

## RELATED PRODUCTS

**Similar products:** 2-486

Use the Index Code at [industrilas.com](http://industrilas.com)

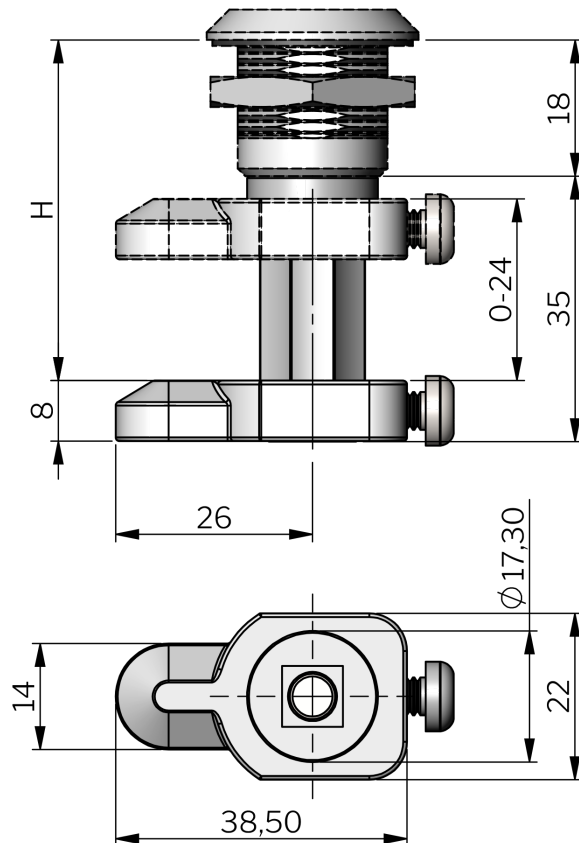

P/N	Description	Cam length
2323-0200-214526	For Vibration Resistant - without projection	26 mm
2323-0200-214545	For Vibration Resistant - without projection	45 mm
2323-0201-214526	For Classic - with projection	26 mm
2323-0201-214545	For Classic - with projection	45 mm

**Industrilas**  
— When access counts —

**Grip Range**

**12 mm housing 18 mm housing 30 mm housing 45 mm housing 56 mm housing**

H min	H max	H min	H max	H min	H max	H min	H max	H min	H max
15.5	39.0	21.5	45.0	33.5	57.0	48.5	72.0	59.5	83.0

