

# ADJUSTABLE ROLLER CAM



Adjustable roller cam that can be assembled on all quarter-turn latches for combi cut-out including L-handles, T-handles and knobs. Available both for latches requiring cam with projection and for latches requiring cams without projection. Provides 48 mm adjustability and between 4 - 52 mm for latches with 18 mm housing depth. Cam is secured at chosen grip range with a set-screw.

Both set-screw and screw to attach the adjustable roller cam to the latch are supplied as Phillips head screws.



## MATERIAL

**Cam:** Zinc die cast, zinc plated

**Roller:** Glass fibre reinforced polyamide (PA6GF30)

**Screw:** Steel, zinc plated

## RELATED PRODUCTS

**Similar products:** 2-485

Use the Index Code at [industrilas.com](http://industrilas.com)

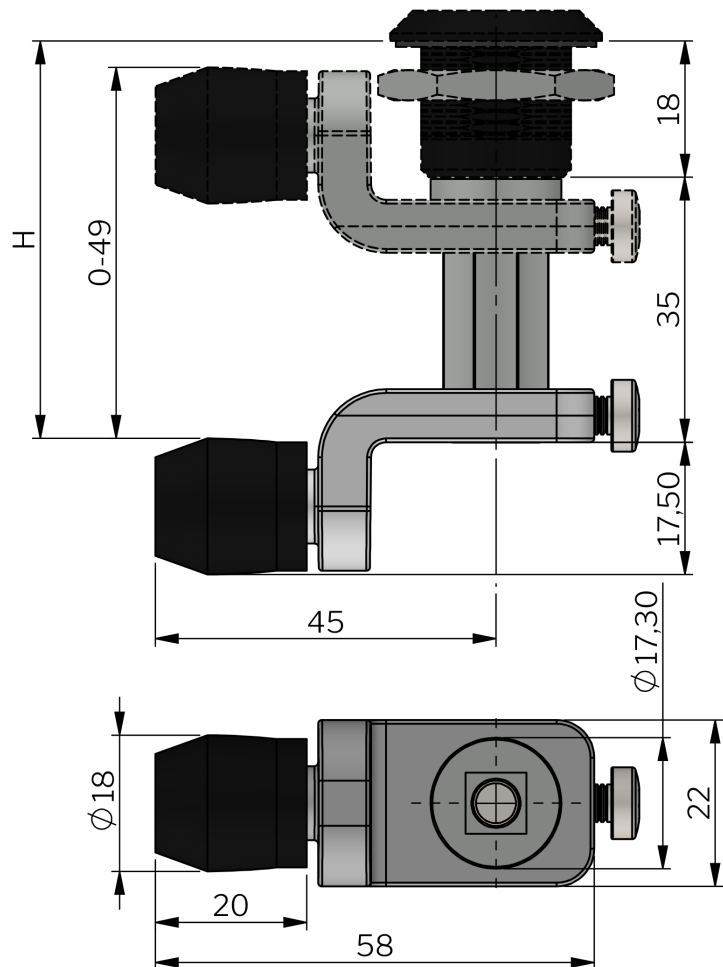

**Industrilas**  
— When access counts —

P/N	Description
2323-0100-214545	For Vibration Resistant - without projection
2323-0101-214545	For Classic - with projection

**Grip Range**

**12 mm housing 18 mm housing 30 mm housing 45 mm housing 56 mm housing**

H min	H max	H min	H max	H min	H max	H min	H max	H min	H max
0.0	46.5	4.0	52.5	16.0	64.5	31.0	79.5	42.0	90.5